

Dual Output Driver

FEATURES

- Dual, 1.5A Totem Pole Outputs
- 40nsec Rise and Fall into 1000pF
- Parallel or Push-Pull Operation
- Single-Ended to Push-Pull Conversion
- High-Speed, Power MOSFET Compatible
- Low Cross-Conduction Current Spike
- Analog, Latched Shutdown
- Internal Deadband Inhibit Circuit
- Low Quiescent Current
- 5 to 40V Operation
- Thermal Shutdown Protection
- 16-Pin Dual-In-Line Package
- 20-Pin Surface Mount Package

DESCRIPTION

The UC1706 family of output drivers are made with a high-speed Schotky process to interface between low-level control functions and high-power switching devices - particularly power MOSFET's. These devices implement three generalized functions as outlined below.

First: They accept a single-ended, low-current digital input of either polarity and process it to activate a pair of high-current, totem pole outputs which can source or sink up to 1.5A each.

Second: They provide an optional single-ended to push-pull conversion through the use of an internal flip-flop driven by double-pulse-suppression logic. With the flip-flop disabled, the outputs work in parallel for 3.0A capability.

Third: Protection functions are also included for pulse-by-pulse current limiting, automatic deadband control, and thermal shutdown.

These devices are available in a two-watt plastic "bat-wing" DIP for operation over a 0°C to 70°C temperature range and, with reduced power, in a hermetically sealed cerdip for -55°C to +125°C operation. Also available in surface mount Q and L packages.

TRUTH TABLE

INV	N.I	OUT
H	H	L
L	H	H
H	L	L
L	L	L

$OUT = \overline{INV}$ and N.I.
 $\overline{OUT} = INV$ or $\overline{N.I.}$

BLOCK DIAGRAM

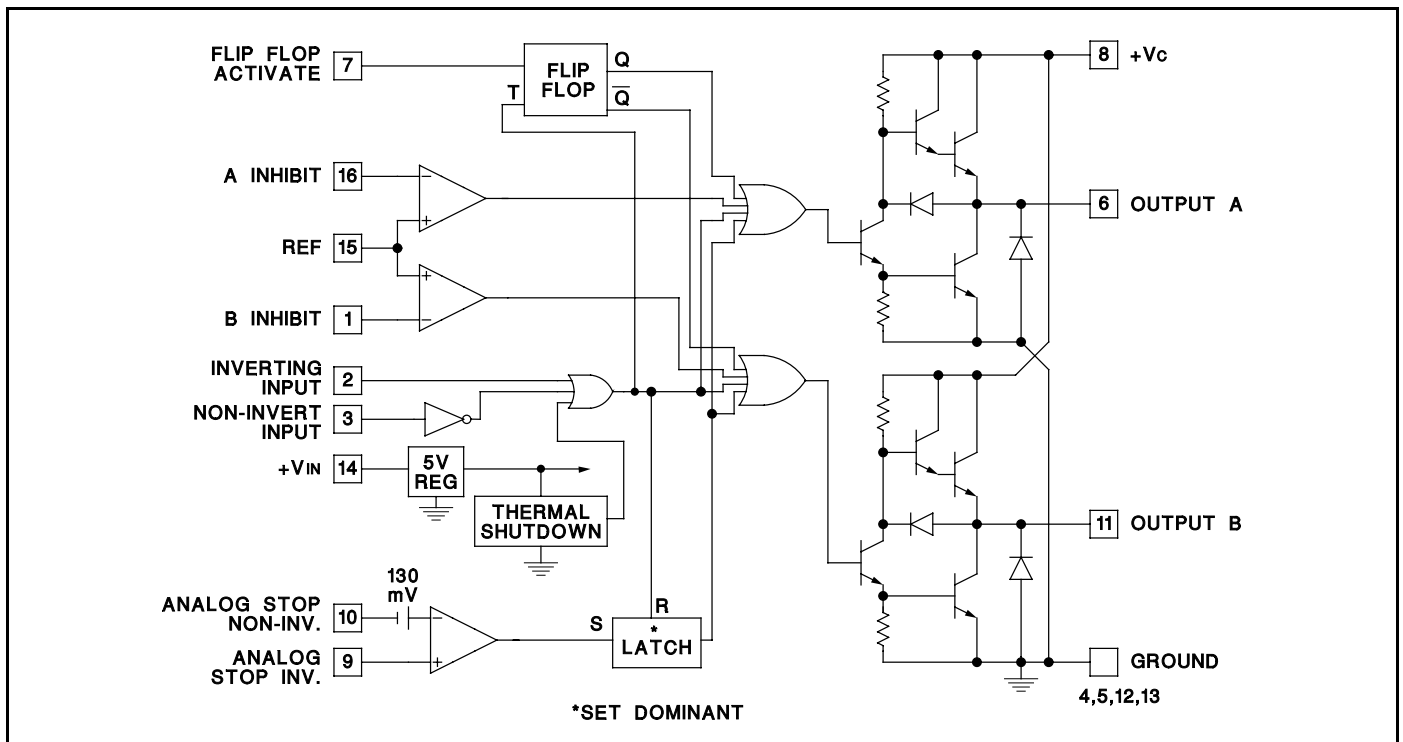

ABSOLUTE MAXIMUM RATINGS

	N-Pkg	J-Pkg
Supply Voltage, V_{IN}	40V	40V
Collector Supply Voltage, V_c	40V	40V
Output Current (Each Output, Source or Sink)		
Steady-State	$\pm 500\text{mA}$	$\pm 500\text{mA}$
Peak Transient	$\pm 1.5\text{A}$	$\pm 1.0\text{A}$
Capacitive Discharge Energy	20 μJ	15 μJ
Digital Inputs	5.5V	5.5V
Analog Stop Inputs	V_{IN}	V_{IN}
Power Dissipation at $T_A = 25^\circ\text{C}$ (See Note)	2W	1W
Power Dissipation at T (Leads/Case) = 25°C (See Note)	2W	2W
Operating Temperature Range	-55°C to $+125^\circ\text{C}$	
Storage Temperature Range	-65°C to $+150^\circ\text{C}$	
Lead Temperature (Soldering, 10 Seconds)	300 $^\circ\text{C}$	

Note: All voltages are with respect to the four ground pins which must be connected together. All currents are positive into, negative out of the specified terminal. Consult Packaging section of Databook for thermal limitations and considerations of package.

CONNECTION DIAGRAMS

**DIL-16, SOIC-16
(TOP VIEW)**
J or N Package, DW Package

Note: All four ground pins must be connected to a common ground.

**PLCC-20, LCC-20
(TOP VIEW)**
Q, L Packages

PACKAGE PIN FUNCTION	
FUNCTION	PIN
N/C	1
B INHIBIT	2
INV INPUT	3
N.I. INPUT	4
GROUND	5
N/C	6
GROUND	7
A OUTPUT	8
FLIP/FLOP	9
V_c	10
N/C	11
STOP NON-INV.	12
STOP INV.	13
B OUTPUT	14
GROUND	15
N/C	16
GROUND	17
V_{IN}	18
INHIBIT REF	19
A INHIBIT	20

ELECTRICAL CHARACTERISTICS: Unless otherwise stated, these specifications apply for $T_A = -55^\circ\text{C}$ to $+125^\circ\text{C}$ for the UC1706, -25°C to $+85^\circ\text{C}$ for the UC2706 and 0°C to $+70^\circ\text{C}$ for the UC3706; $V_{IN} = V_c = 20\text{V}$. $T_A = T_J$.

PARAMETERS	TEST CONDITIONS	MIN	TYP	MAX	UNITS
V_{IN} Supply Current	$V_{IN} = 40\text{V}$		8	10	mA
V_c Supply Current	$V_c = 40\text{V}$, Outputs Low		4	5	mA
V_c Leakage Current	$V_{IN} = 0$, $V_c = 30\text{V}$, No Load		.05	0.1	mA
Digital Input Low Level				0.8	V
Digital Input High Level		2.2			V
Input Current	$V_I = 0$		-0.6	-1.0	mA
Input Leakage	$V_I = 5\text{V}$.05	0.1	mA
Output High Sat., $V_c - V_o$	$I_o = -50\text{mA}$			2.0	V
	$I_o = -500\text{mA}$			2.5	V

ELECTRICAL CHARACTERISTICS (cont.):

Unless otherwise stated, these specifications apply for $T_A = -55^{\circ}\text{C}$ to $+125^{\circ}\text{C}$ for the UC1706, -25°C to $+85^{\circ}\text{C}$ for the UC2706 and 0°C to $+70^{\circ}\text{C}$ for the UC3706; $V_{IN} = V_C = 20\text{V}$. $T_A = T_J$.

PARAMETERS	TEST CONDITIONS	MIN	TYP	MAX	UNITS
Output Low Sat., V_o	$I_o = 50\text{mA}$			0.4	V
	$I_o = 500\text{mA}$			2.5	V
Inhibit Threshold	$V_{REF} = 0.5\text{V}$	0.4		0.6	V
	$V_{REF} = 3.5\text{V}$	3.3		3.7	V
Inhibit Input Current	$V_{REF} = 0$		-10	-20	μA
Analog Threshold	$V_{CM} = 0$ to 15V	100	130	150	mV
Input Bias Current	$V_{CM} = 0$		-10	-20	μA
Thermal Shutdown			155		$^{\circ}\text{C}$

TYPICAL SWITCHING CHARACTERISTICS: $V_{IN} = V_C = 20\text{V}$, $T_A = 25^{\circ}\text{C}$. Delays measured to 10% output change.

PARAMETERS	TEST CONDITIONS	OUTPUT $C_L =$			UNIT
From Inv. Input to Output:		open	1.0	2.2	nF
Rise Time Delay		110	130	140	ns
10% to 90% Rise		20	40	60	ns
Fall Time Delay		80	90	110	ns
90% to 10% Fall		25	30	50	ns
From N. I. Input to Output:					
Rise Time Delay		120	130	140	ns
10% to 90% Rise		20	40	60	ns
Fall Time Delay		100	120	130	ns
90% to 10% Fall		25	30	50	ns
V_C Cross-Conduction Current Spike Duration	Output Rise	25			ns
	Output Fall	0			ns
Inhibit Delay	Inhibit Ref. = 1V , Inhibit Inv. = 0.5 to 1.5V	250			ns
Analog Shutdown Delay	Stop Non-Inv. = 0V , Stop Inv. = 0 to 0.5V	180			ns

CIRCUIT DESCRIPTION

Outputs

The totem-pole outputs have been designed to minimize cross-conduction current spikes while maximizing fast, high-current rise and fall times. Current limiting can be done externally either at the outputs or at the common V_C pin. The output diodes included have slow recovery and should be shunted with high-speed external diodes when driving high-frequency inductive loads.

Flip/Flop

Grounding pin 7 activates the internal flip-flop to alternate the two outputs. With pin 7 open, the two outputs operate simultaneously and can be paralleled for higher current operation. Since the flip-flop is triggered by the digital input, an off-time of at least 200nsec must be provided to allow the flip/flop to change states. Note that the circuit logic is configured such that the "OFF" state is defined as the outputs low.

Digital Inputs

With both an inverting and non-inverting input available, either active-high or active-low signals may be accepted. These are true TTL compatible inputs--the threshold is

approximately 1.2V with no hysteresis; and external pull-up resistors are not required.

Inhibit Circuit

Although it may have other uses, this circuit is included to eliminate the need for deadband control when driving relatively slow bipolar power transistors. A diode from each inhibit input to the opposite power switch collector will keep one output from turning-on until the other has turned-off. The threshold is determined by the voltage on pin 15 which can be set from 0.5 to 3.5V. When this circuit is not used, ground pin 15 and leave 1 and 16 open.

Analog Shutdown

This circuit is included to get a latched shutdown as close to the outputs as possible, from a time standpoint. With an internal 130mV threshold, this comparator has a common-mode range from ground to $(V_{IN} - 3\text{V})$. When not used, both inputs should be grounded. The time required for this circuit to latch is inversely proportional to the amount of overdrive but reaches a minimum of 180nsec. As with the flip-flop, an input off-time of at least 200nsec is required to reset the latch between pulses.

CIRCUIT DESCRIPTION (cont.)

Supply Voltage

With an internal 5V regulator, this circuit is optimized for use with a 7 to 40V supply; however, with some slight response time degradation, it can also be driven from 5V. When V_{IN} is low, the entire circuit is disabled and no current is drawn from V_c . When combined with a UC1840 PWM, the Driver Bias switch can be used to supply V_{IN}

to the UC1706. V_{IN} switching should be fast as if V_c is high, undefined operation of the outputs may occur with V_{IN} less than 5V.

Thermal Considerations

Should the chip temperature reach approximately 155°C, a parallel, non-inverting input is activated driving both outputs to the low state.

APPLICATIONS

Power MOSFET Drive Circuit

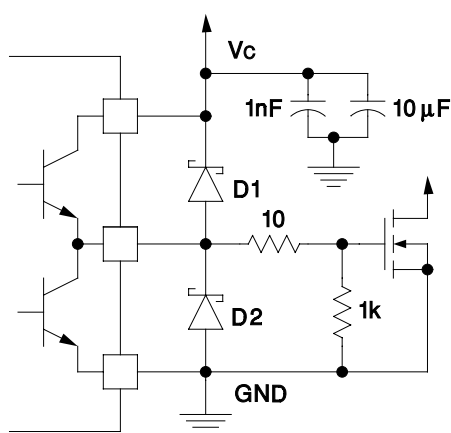

D1, D2: UC3611 Schottky Diodes

Power MOSFET Drive Circuit Using Negative Bias Voltage and Level Shifting to Ground Referenced PWMs.

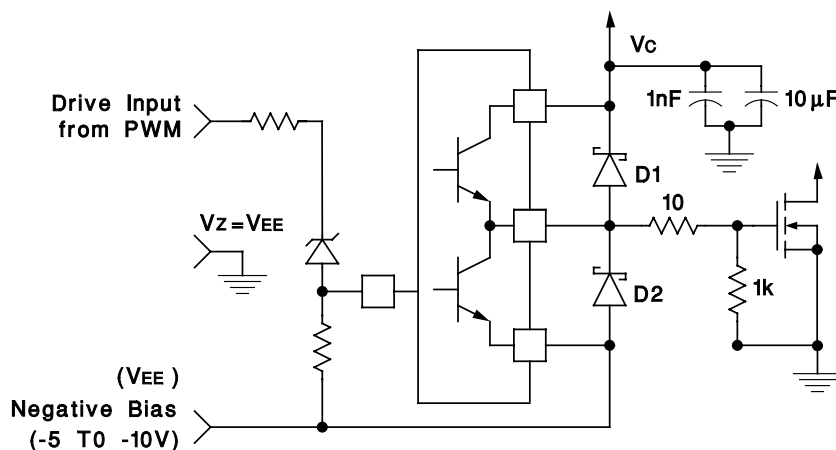

D1, D2: UC3611 Schottky Diodes

Transformer Coupled MOSFET Drive Circuit

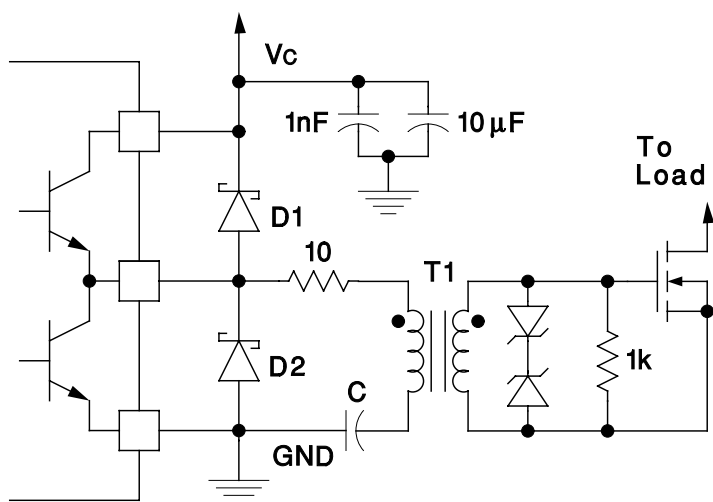

D1, D2: UC3611 Schottky Diodes

Charge Pump Circuits

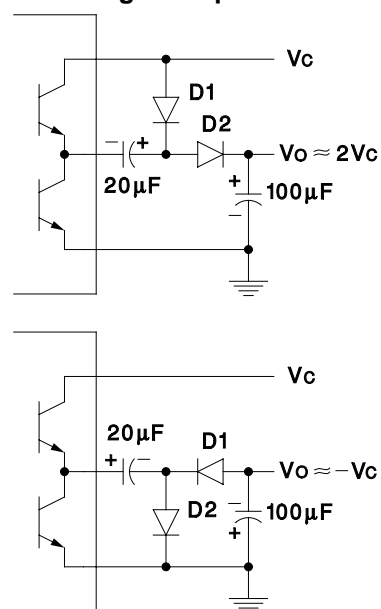

APPLICATIONS (cont'd)

